



## Description

The Salvo Glad Hand Lock can be attached to the emergency glad hand fitting of the truck trailer. Once attached, the trapped Castell key is released and can be inserted into the Salvo Manual Door Lock or Salvo Control Panel.

## Application

The Salvo Glad Hand Lock helps ensure loading dock safety. After the operator has unhooked the truck's emergency brake, the Salvo Glad Hand Lock can be attached to the truck trailer, releasing the trapped Castell key. The truck is unable to depart until the key is replaced and the Salvo Glad Hand Lock is removed, allowing the brake lines to once again be engaged and operational.

## Technical Data

<b>Temperature Rating</b>	min -20° F / max 130° F
<b>Product Material</b>	Brass and stainless steel
<b>Dimensions</b>	2.25" H x 10" W x 2.25" D
<b>Weight</b>	4.5 lb

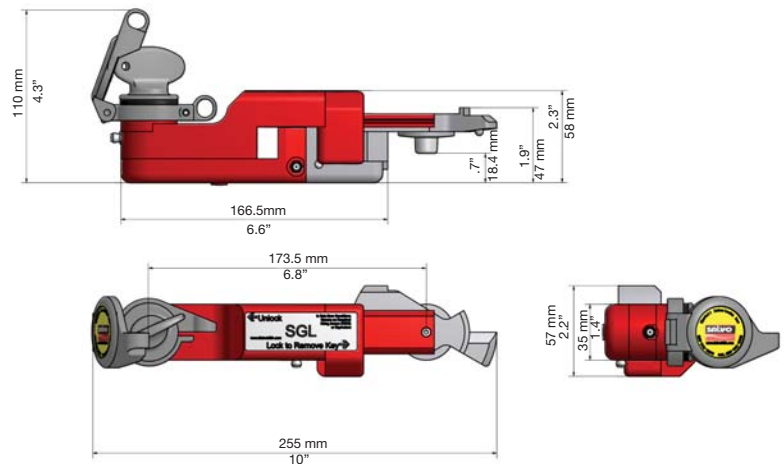

## Order Information

P/N	Description
510.0012	Salvo Glad Hand Lock

## Contact Information

Castell Interlocks, Inc.  
 21 Kenton Lands Road  
 Erlanger, KY 41018  
 phone: +1.859.341.3075  
 fax: +1.859.957.1577  
 toll free: +1.877.341.3075  
 www.castell.com

580.0012



### Description

The Salvo Club helps ensure loading dock safety. The Salvo Club brings added safety to loading dock procedures by locking a vehicle's steering wheel. The Salvo Club can be attached to vehicle steering wheels of varying sizes and will remain locked in place once the Castell key is removed. When loading/unloading procedures are complete, the Castell key may be replaced, and the Salvo Club can be removed allowing the vehicle driver to depart from the loading dock.

### Application

The Salvo Club can be used in conjunction with other Salvo products to stop accidents before they happen. By attaching the Salvo Club to the vehicle's steering wheel, it becomes locked in place and eliminates human error caused by unscheduled departure. The Salvo Club also prevents the vehicle against theft.

### Technical Data

<b>Product Material</b>	Steel/Cro-moly steel construction with heat treated solid steel hooks
<b>Lock and Key Material</b>	Stainless steel ( FS - Lock )
<b>Min Steering Wheel Size</b>	9" Internal Diameter
<b>Max Steering Wheel Size</b>	19" Internal Diameter

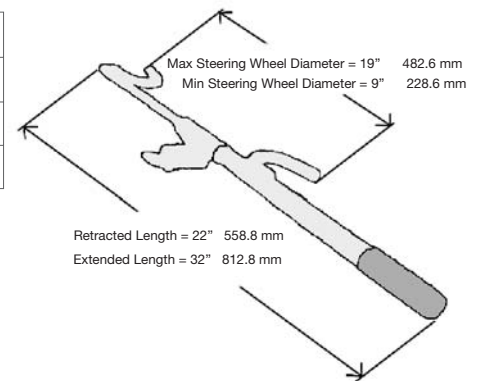

### Order Information

P/N	Description
510.0008	Salvo Club

### Contact Information

Castell Interlocks, Inc.  
 21 Kenton Lands Road  
 Erlanger, KY 41018  
 phone: +1.859.341.3075  
 fax: +1.859.957.1577  
 toll free: +1.877.341.3075  
 www.castell.com

580.0006



## Description

The SCP offers 1" diameter red and green communication lights designed to interlock with the door operator's limit switches. The red communication light is displayed when the SADL is engaged. The green communication light is displayed when the SADL is disengaged, trapping the Castell key. When the SADL is reengaged, the red communication light is displayed and the yellow LED can then be pressed, which releases the Castell key.

## Application

The Salvo Control Panel is used as part of the Salvo Automatic Door system in conjunction with the SADL. It also easily connects to the Salvo Internal and External Traffic Lights or can be wired to an automatic door's motor relay. Mounted on the outside of a building, the Salvo Control Panel traps the Castell key when an overhead door is open and the green communication light is displayed. When the overhead door is closed, the red communication light is displayed and the Castell key can be removed.

## Technical Data

<b>Temperature Rating</b>	min -22° F / max 130° F
<b>Dimensions</b>	12" H x 8" W x 6" D
<b>Weight</b>	18 lb
<b>Voltage</b>	110V AC
<b>Color</b>	RAL 7035 (Light Grey)
<b>Material</b>	Powder Coated Mild Steel
<b>Rating</b>	IP65, NEMA 4 Enclosure

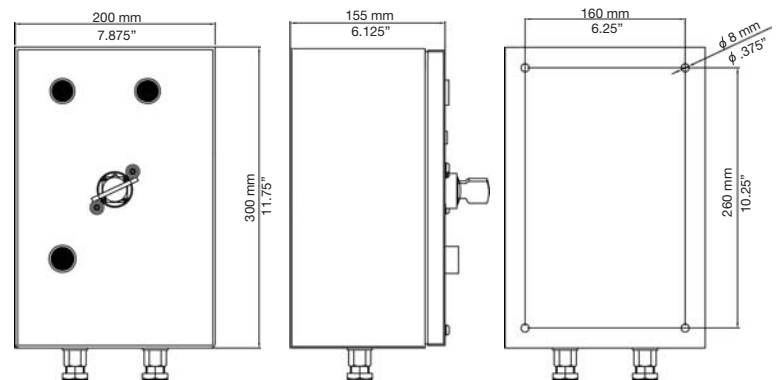

## Order Information

P/N	Description
510.0033	Salvo Control Panel

## Contact Information

Castell Interlocks, Inc.  
 21 Kenton Lands Road  
 Erlanger, KY 41018  
 phone: +1.859.341.3075  
 fax: +1.859.957.1577  
 toll free: +1.877.341.3075  
 www.castell.com

580.0010



### Description

The Salvo Automatic Door Lock works in conjunction with the Salvo Control Panel to help ensure loading dock safety. The locking mechanism is a heavy duty stainless steel tongue.

### Application

The Salvo Automatic Door Lock helps ensure loading dock safety. Mounted inside the building on the overhead door or Salvo Bollard, the Salvo Automatic Door Lock is linked to a Salvo Control Panel. When the door lock is disengaged the Castell key is trapped in the Salvo Control Panel. When the door lock is engaged, the key is released.

### Technical Data

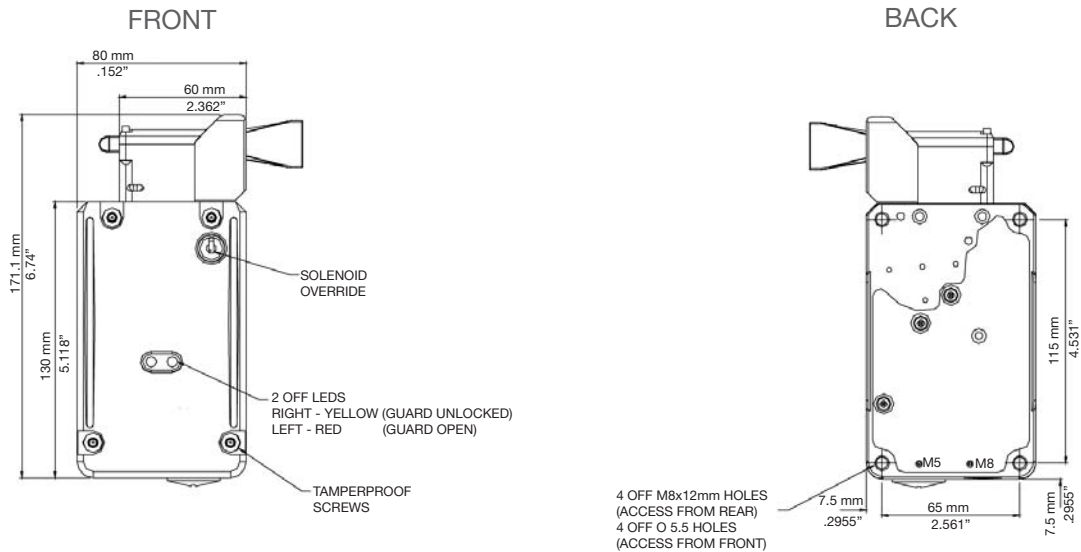

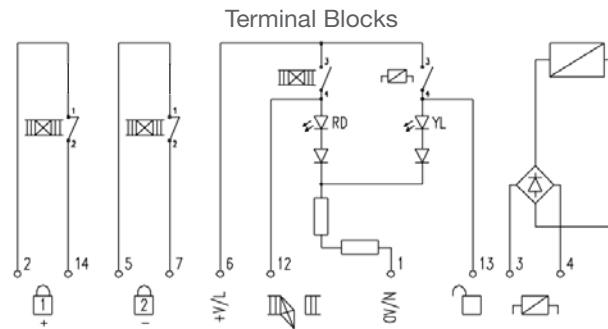

### Terminals

<b>Terminal 1</b>	ØV/N	<b>Terminal 6</b>	+V/L
<b>Terminal 2</b>	Output 1	<b>Terminal 7</b>	Output 2
<b>Terminal 3</b>	Solenoid power	<b>Terminal 12</b>	Tongue Position Feedback
<b>Terminal 4</b>	Solenoid power	<b>Terminal 13</b>	Solenoid Feedback
<b>Terminal 5</b>	Output 2	<b>Terminal 14</b>	Output 1

### SADL Automatic Door Lock Specifications

<b>Material</b>	Zinc alloy, stainless steel	<b>Switch Conformance</b>	DIN VDE 0660 Part 206 & IEC
<b>Finishing</b>	Gloss polyester powder coat on passivated base material	<b>Switching Contact Element</b>	4NC and 2NO
<b>Color</b>	Red, black, and stainless steel	<b>Switching Principal</b>	Positive Break
<b>Ingress Protection</b>	IP67 (DIN400050)	<b>Switch Control</b>	3A
<b>Operating Force</b>	0.5N	<b>Switching Voltage</b>	230V AC Max
<b>Retention Force Locked</b>	2,500 N	<b>Isolating Distance</b>	2x2 mm per switch element
<b>Maximum Approach Speed</b>	20 m/minutes	<b>Contact material</b>	90% silver and 10% nickel
<b>Minimum Door Radius</b>	900 mm	<b>Utilization Category</b>	AC 15 or DC 13
<b>Mechanical Life</b>	>1,000,000 switching cycles	<b>Control Voltage</b>	24V AC/DC
<b>Maximum Frequency of Ops</b>	7,200 hour/hour	<b>Insulating Resistance</b>	20 M 0 hm
<b>Ambient Temperature</b>	-5 ~ 40°C (mean over 24 hrs = +35°C)	<b>Insulating Voltage</b>	2.500V AC
<b>Maximum Wire Cross-Section to Fit Connector</b>	2.50 mm <sup>2</sup>	<b>Solenoid Power Rating</b>	12W (solenoid current at nominal 500 mA; quasient current = 350mA)
<b>Connector Type</b>	Spring activated vibration proof block	<b>Solenoid Rating (Duty Cycle)</b>	100%
		<b>Solenoid Voltage</b>	24V DC
		<b>Solenoid Voltage Tolerance</b>	90% to 110% of nominal

### Order Information

#### P/N

510.0037

#### Description

Salvo Automatic Door Lock

### Contact Information

Castell Interlocks, Inc.  
21 Kenton Lands Road  
Erlanger, KY 41018

phone: +1.859.341.3075  
fax: +1.859.957.1577  
toll free: +1.877.341.3075  
www.castell.com

580.0007

# SADL-A

## Salvo Automatic Door Lock with Key Adapter



### Description

Salvo SADL-A has a heavy duty tongue and head that allow it to withstand the rigors of a loading dock. The tongue and head unit can rotate in 90 degree increments. It has a key operated auxiliary release in the event of a power failure. The product is ideally designed for loading docks where an additional level of safety is preferred.

Safety Key Adaptor ensures that the forklift driver cannot be on a truck trailer and have the chain or door closed behind them.

### Operation

When the tongue is engaged, the safety key is trapped. The integral solenoid prevents the safety key from being removed until the solenoid is energized. On the SADL-A modules, a yellow LED will illuminate when the solenoid has been energized and the key can be removed. When the Safety Key is removed, a green LED will illuminate on the interlock indicating that there is a safe state. The forklift operator can then take the Safety Key into the trailer, preventing an inadvertent release of the trailer. The Safety Key cannot be replaced until the tongue is engaged in the interlock.

### Technical Data

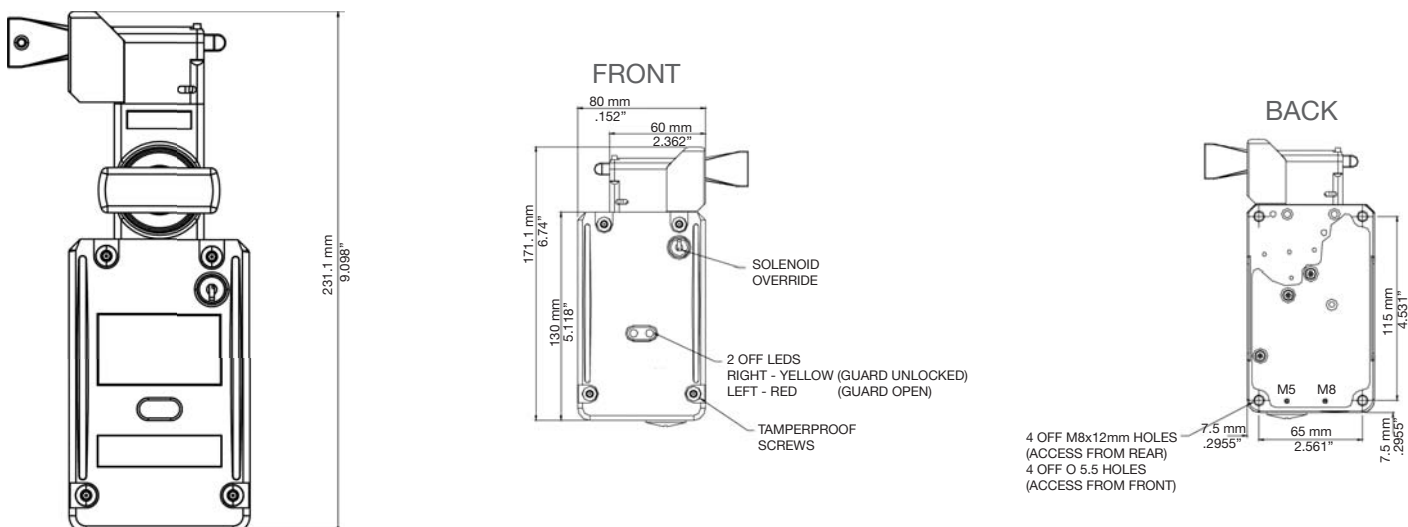

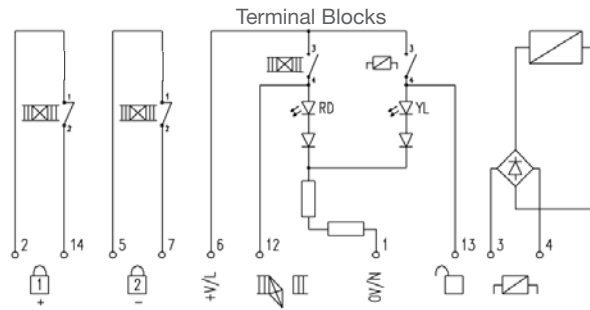

## Terminals

Terminal 1	ØV/N	Terminal 6	+V/L
Terminal 2	Output 1	Terminal 7	Output 2
Terminal 3	Solenoid power	Terminal 12	Tongue Position Feedback
Terminal 4	Solenoid power	Terminal 13	Solenoid Feedback
Terminal 5	Output 2	Terminal 14	Output 1

## SADL-A Automatic Door Lock Specifications

<b>Material</b>	Zinc alloy, stainless steel	<b>Switch Conformance</b>	DIN VDE 0660 Part 206 & IEC
<b>Finishing</b>	Gloss polyester powder coat on passivated base material	<b>Switching Contact Element</b>	4NC and 2NO
<b>Color</b>	Red, black, and stainless steel	<b>Switching Principal</b>	Positive Break
<b>Ingress Protection</b>	IP67 (DIN400050)	<b>Switch Control</b>	3A
<b>Operating Force</b>	0.5N	<b>Switching Voltage</b>	230V AC Max
<b>Retention Force Locked</b>	2,500 N	<b>Isolating Distance</b>	2x2 mm per switch element
<b>Maximum Approach Speed</b>	20 m/minutes	<b>Contact material</b>	90% silver and 10% nickel
<b>Minimum Door Radius</b>	900 mm	<b>Utilization Category</b>	AC 15 or DC 13
<b>Mechanical Life</b>	>1,000,000 switching cycles	<b>Control Voltage</b>	24V AC/DC
<b>Maximum Frequency of Ops</b>	7,200 hour/hour	<b>Insulating Resistance</b>	20 M 0 hm
<b>Ambient Temperature</b>	-5 ~ 40°C (mean over 24 hrs = +35°C)	<b>Insulating Voltage</b>	2.500V AC
<b>Maximum Wire Cross-Section to Fit Connector</b>	2.50 mm <sup>2</sup>	<b>Solenoid Power Rating</b>	12W (solenoid current at nominal 500 mA; quasient current = 350mA)
<b>Connector Type</b>	Spring activated vibration proof block	<b>Solenoid Rating (Duty Cycle)</b>	100%
		<b>Solenoid Voltage</b>	24V DC
		<b>Solenoid Voltage Tolerance</b>	90% to 110% of nominal

## Order Information

### P/N

510.0037

### Description

Salvo Automatic Door Lock with Adaptor

## Contact Information

Castell Interlocks, Inc.  
21 Kenton Lands Road  
Erlanger, KY 41018

phone: +1.859.341.3075  
fax: +1.859.957.1577  
toll free: +1.877.341.3075  
www.castell.com

580.0008

# SMDL-SDMC

## Salvo Door Manual Chain



### Description

The standard bolt of the Salvo Manual Door Lock is stainless steel and is mounted on the left-hand side of the door. For increased flexibility, the Salvo Manual Door Lock can be equipped with a chain-mounted bolt in order to be used with a Salvo Barrier Chain.

### Application

The Salvo Manual Door Lock helps ensure loading dock safety. Mounted on an overhead door or Salvo Bollard inside the building, the Salvo Manual Door Lock can work in conjunction with the Salvo Barrier Chain to prevent unscheduled departures. When the Castell key is inserted into the Salvo Manual Door Lock, the bolt can be removed and the door opened. When the door is closed, the bolt is replaced and the key is released.

### Technical Data

<b>Temperature Rating</b>	min -40° F / max 280° F
<b>Product Material</b>	Stainless steel
<b>Lock Dimensions</b>	2.75" H x 3.5" W x 2.5" D
<b>Bolt Dimensions</b>	13" long, 5" wide
<b>Weight</b>	2.42 lb

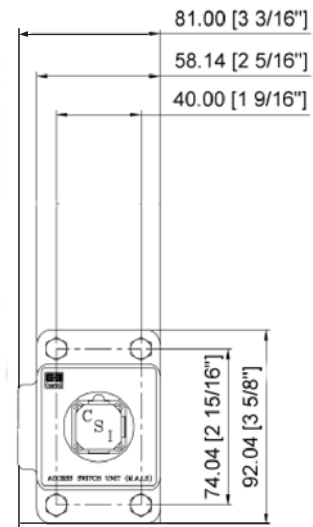

### Order Information

P/N	Description
510.0034	SMDL - R Salvo Manual Door Lock Right Hand with Chain
510.0042	SMDL - L Salvo Manual Door Lock Left Hand with Chain

### Contact Information

Castell Interlocks, Inc.  
21 Kenton Lands Road  
Erlanger, KY 41018  
phone: +1.859.341.3075  
fax: +1.859.957.1577  
toll free: +1.877.341.3075  
www.castell.com

580.0016



# SMDL-SDMB

## Salvo Door Manual Bolt

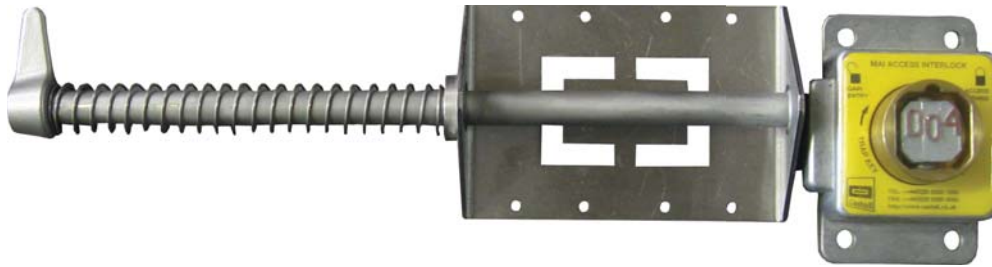

### Description

The standard bolt of the Salvo Door Manual Bolt is stainless steel and is mounted on the left-hand side of the door.

### Application

The Salvo Manual Door Lock helps ensure loading dock safety. Mounted on an overhead door or Salvo Bollard inside the building, the Salvo Manual Door Lock can work in conjunction with the Salvo Barrier Chain to prevent unscheduled departures. When the Castell key is inserted into the Salvo Manual Door Lock, the bolt can be removed and the door opened. When the door is closed, the bolt is replaced and the key is released.

### Technical Data

<b>Temperature Rating</b>	min -40° F / max 280° F
<b>Product Material</b>	Stainless steel
<b>Lock Dimensions</b>	2.75" H x 3.5" W x 2.5" D
<b>Bolt Dimensions</b>	13" long, 5" wide
<b>Weight</b>	2.42 lb

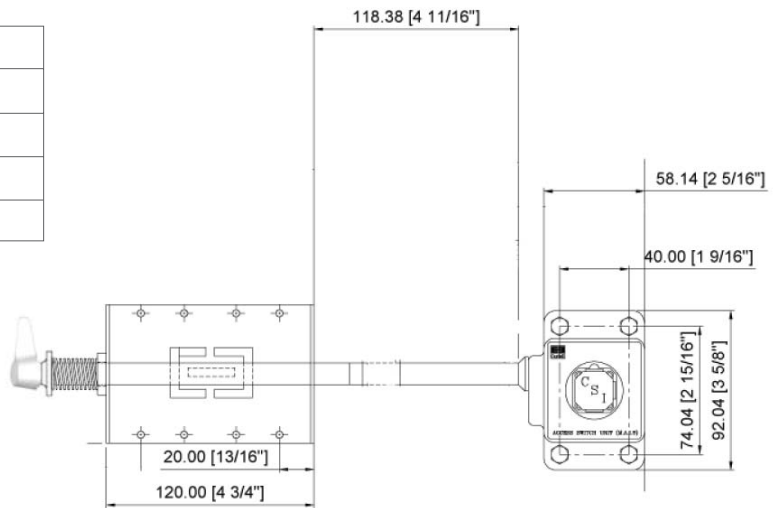

### Order Information

#### P/N

510.0041

#### Description

Salvo Manual Door Lock with Bolt

### Contact Information

Castell Interlocks, Inc.  
21 Kenton Lands Road  
Erlanger, KY 41018

phone: +1.859.341.3075  
fax: +1.859.957.1577  
toll free: +1.877.341.3075  
www.castell.com

580.0015



## Description

The standard bolt of the Salvo Manual Door Lock with Electric Interlock is stainless steel and is mounted on the left-hand side of the door. For increased flexibility, the SMDL-EI can be equipped with a chain-mounted bolt in order to be used with a Salvo Barrier Chain.

## Application

The Salvo Manual Door Lock with Electric Interlock helps ensure loading dock safety. Mounted on an overhead door or Salvo Bollard inside the building, the SMDL-EI can be electrically interlocked with another piece of dock equipment.

## Technical Data

<b>Temperature Rating</b>	min -20° F / max 175° F
<b>Product Material</b>	Aluminum and stainless steel
<b>Lock Dimensions</b>	2.75" H x 3.5" W x 2.5" D
<b>Bolt Dimensions</b>	13" long, 5" wide
<b>Weight</b>	2.5 lb
<b>Current/Voltage</b>	10A / max 500V
<b>Mechanical Life Cycle</b>	200,000 electrical operations
<b>Switch Contact</b>	2 x N.O. (Normally Open) 1 x N.C. (Normally Closed)

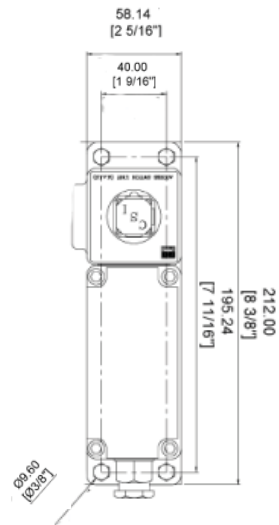

## Order Information

P/N	Description
510.0036	SMDL - Electric Interlock Right / Hand-2
510.0044	SMDL - Electric Interlock Left / Hand-1

## Contact Information

Castell Interlocks, Inc.  
21 Kenton Lands Road  
Erlanger, KY 41018  
phone: +1.859.341.3075  
fax: +1.859.957.1577  
toll free: +1.877.341.3075  
www.castell.com



### Description

The Salvo Adjustable Manual Lock Bracket (SAMLB) helps ensure loading dock safety by working in conjunction with other Salvo products. The SAMLB is easy to install by bolting it to the wall. Its adjustable feature makes it simple to align at the loading dock. Various products mount to the SAMLB to stop accidents before they happen.

### Application

SBC  
Salvo Barrier Chain Kit



SMDL-EI  
Salvo Manual Door with  
Electrical Interlock



SMDL  
Salvo Manual Door Lock



### Technical Data

<b>Product Material</b>	Mild Steel
<b>Color</b>	OSHA Safety Yellow
<b>Dimensions</b>	8.386" H x 3.15" W x 3.5" - 5" D (adjustable)
<b>Weight</b>	4.5 lb

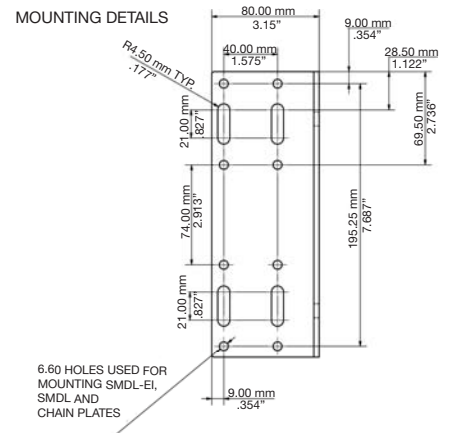
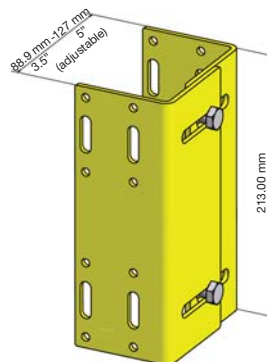

### Order Information

#### P/N

510.0018

#### Description

Salvo Adjustable Manual Lock Bracket

### Contact Information

Castell Interlocks, Inc.  
21 Kenton Lands Road  
Erlanger, KY 41018

phone: +1.859.341.3075  
fax: +1.859.957.1577  
toll free: +1.877.341.3075  
www.castell.com

580.0020



### Description

SMDL model shown

The Salvo Bollard has many applications that help ensure loading dock safety. The Salvo Bollard can be equipped with several different Salvo products to stop accidents before they happen. It can be mounted on existing or newly poured concrete by attaching the post to a mounting bracket on the ground.

### Applications



**SMDL**  
Salvo Bollard with Manual Door Lock

Manual door lock mounts to bollard and works in conjunction with Salvo Bollard with Chain.



**SBC**  
Salvo Bollard with Barrier Chain

Bracket and chain can be mounted to bollard and connect to bollard-mounted manual or automatic door lock (as shown above).



**SGLE**  
Salvo Bollard with Storage Box

Designed to store Salvo Glad Hand Lock (SGL) when not in use on a truck trailer.



**SADL**  
Salvo Bollard with Automatic Door Lock

Automatic door lock mounts to bollard and works in conjunction with Salvo Bollard with Chain and connects to the Salvo Automatic Door Lock (SADL).



**SMDL - EI**  
Salvo Bollard with SMDL - EI Lock

SMDL - EI manual lock with electrical contacts mounts to bollard and interlocks with a dock leveler or controls Salvo Internal Traffic Lights (SITL).

### Applications (Cont'd)



**SCP & SGLE**  
Salvo Bollard with Control Panel and Storage Box

Control panel (SCP) mounts on top of the bollard in conjunction with Storage Box (SGLE) mounted to the side.



**SCP**  
Salvo Bollard with Control Panel

Designed to mount Salvo Control Panel (SCP), which interlocks with the door operator's limit controls or controls the Salvo Internal Traffic Lights (SITL).

### Technical Data

<b>Post Material</b>	Powder-coated carbon steel
<b>Cap Material</b>	UV-resistant ABS plastic (black)
<b>Dimensions</b>	40.5" x 4.25" x 6.25"
<b>Weight</b>	35 lb
<b>Color</b>	Safety Yellow
<b>Mounting Hardware</b>	L-anchor, expansion anchor, split washer and nut, SADL mounting plate, SMDL/Chain Plate mount (included)

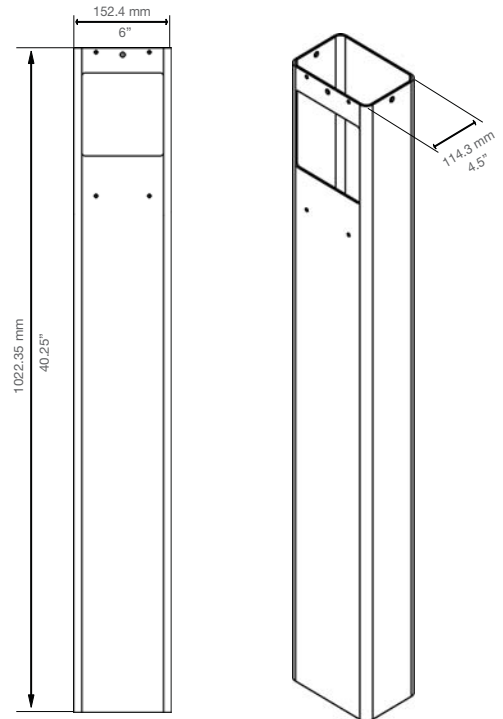

### Order Information

P/N	Description
510.0000	Salvo Bollard

### Contact Information

Castell Interlocks, Inc.  
21 Kenton Lands Road  
Erlanger, KY 41018  
phone: +1.859.341.3075  
fax: +1.859.957.1577  
toll free: +1.877.341.3075  
www.castell.com

580.0005

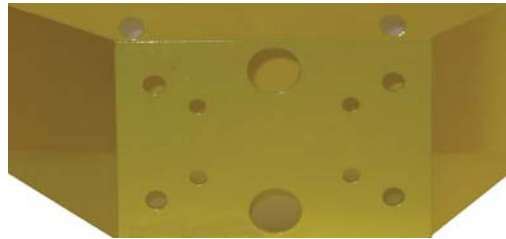

## Description

The Salvo Wall Bracket attaches to the wall and makes it easy to mount various Salvo products as part of a loading dock safety system.

## Application

The Salvo Wall Bracket has pre-positioned holes making it easy to hold any of the mountable Salvo products. The Salvo Wall Bracket is ideally mounted between dock doors to create space for the easy operation of Salvo products.



SADL



SCCP



SMDL w/ Chain

## Technical Data

<b>Product Material</b>	Carbon steel
<b>Color</b>	OSHA Safety Yellow
<b>Dimensions</b>	10.25" H x 12" W x 4.5" D
<b>Weight</b>	9 lb

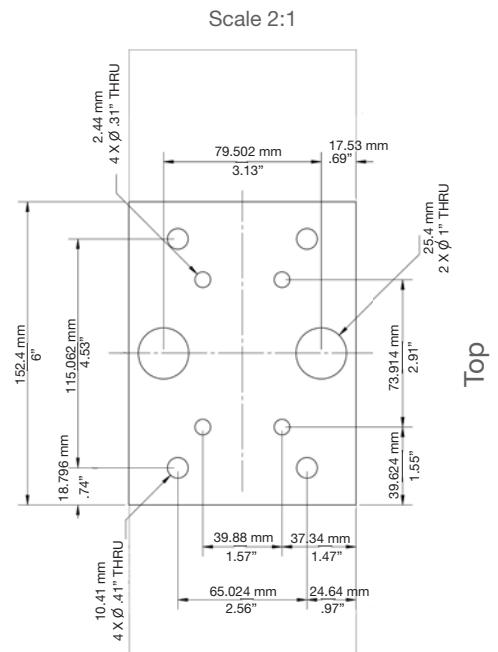
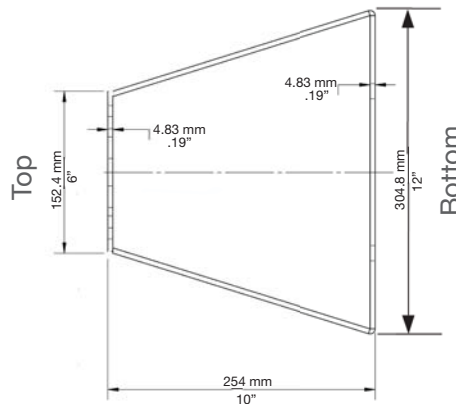
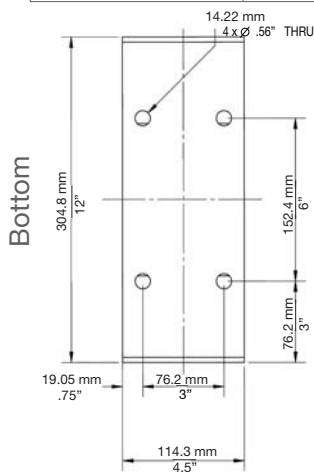

## Order Information

P/N	Description
510.0001	Salvo Wall Bracket

## Contact Information

Castell Interlocks, Inc.  
21 Kenton Lands Road  
Erlanger, KY 41018

phone: +1.859.341.3075  
fax: +1.859.957.1577  
toll free: +1.877.341.3075  
www.castell.com

580.0019



## Description

The Salvo Barrier Chain can be used in conjunction with a Salvo Automatic or Manual Door Lock to help ensure loading dock safety. The SBC consists of three components: the barrier chain plate, the chain link, and the barrier chain. The barrier chain can be cut to length and quickly attached to the barrier chain plate without welding using the one-time close chain link. The Salvo Barrier Chain can be floor-mounted, wall-mounted, or mounted on a Salvo Bollard.

## Application

Part of the Salvo product line, the Salvo Barrier Chain can be used when door-mounted locks are not suitable. Used in conjunction with several Salvo products, the Salvo Barrier Chain is put in place to prevent a forklift driver from leaving the dock when there is no truck at the dock. The Salvo Barrier Chain is ideal for applications where dock doors are left open.

## Technical Data

<b>Type of Mounting</b>	Four M6 security bolts
<b>Plate Material</b>	Stainless Steel
<b>Chain Material</b>	Steel, Powder Coated in OSHA Safety Yellow
<b>Chain Link</b>	Steel, One time closure

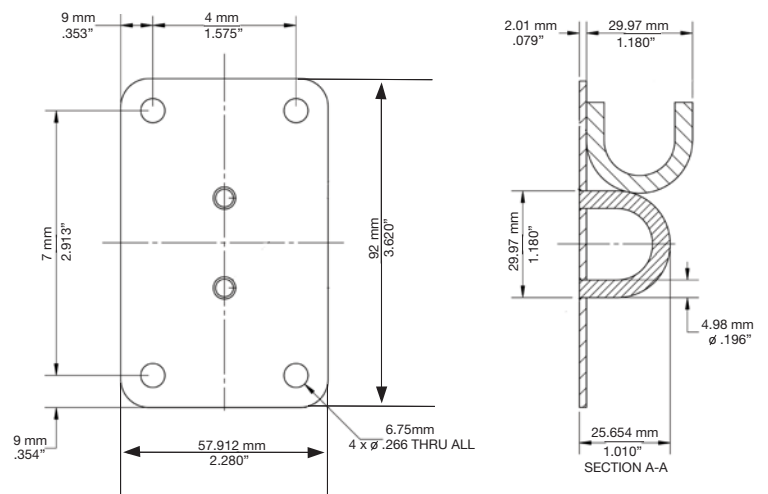

## Order Information

### P/N

510.0006

### Description

Salvo Barrier Chain

## Contact Information

Castell Interlocks, Inc.  
21 Kenton Lands Road  
Erlanger, KY 41018

phone: +1.859.341.3075  
fax: +1.859.957.1577  
toll free: +1.877.341.3075  
www.castell.com

580.0009



## Description

The Salvo Traffic Lights are used where larger red and green lights than those on the Salvo Control Panel are required to warn drivers not to pull away until the green light is on. The lights are ideally located in a highly visible location close to the Salvo Traffic Light Sign.

## Application

The Salvo Traffic Lights can be used in conjunction with the Salvo Traffic Light Sign to improve communication between a dock attendant and truck drivers. Mounted outside in close proximity to the Salvo Traffic Light Sign, the Salvo Traffic Lights are linked to a Salvo Control Panel. The red light indicates that the truck is still being loaded, and the green light inform the driver when it is safe to depart from the loading dock.

## Technical Data

<b>Product Material</b>	Polypropylene
<b>Dimensions</b>	5" H x 6 3/8" W x 4" D
<b>Len Diameter</b>	10 1/4"
<b>Weight</b>	2 lb
<b>Voltage</b>	115V AC
<b>Color</b>	OSHA Safety Yellow

Wire Configuration	
<b>Black (Green)</b>	Green Lamp
<b>White</b>	Ground/Earth
<b>Black (Red)</b>	Red Lamp
<b>Red</b>	Common/Neutral

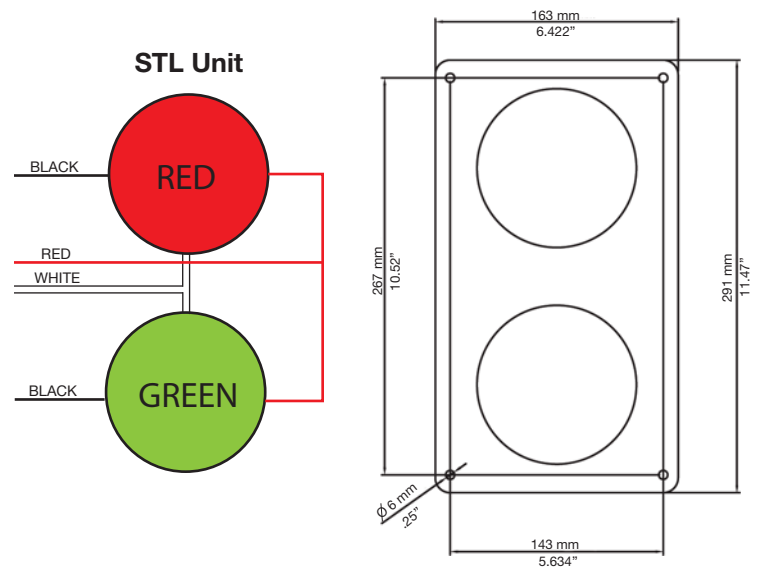

## Order Information

P/N	Description
510.0031	Salvo Traffic Lights

## Contact Information

Castell Interlocks, Inc.  
 21 Kenton Lands Road  
 Erlanger, KY 41018  
 phone: +1.859.341.3075  
 fax: +1.859.957.1577  
 toll free: +1.877.341.3075  
 www.castell.com

580.0011





### Description

The Salvo Traffic Light Sign warns drivers not to pull away until the the green light is on. The sign is ideally located in a highly visible location close to the Salve External Traffic Light. The Salvo Traffic Light Sign contains reflected lettering that makes it easy to read from a truck’s rear view mirrors.

### Application

The Salvo Traffic Light Sign can be used in conjunction with the Salvo External Traffic Light to improve communication and help ensure loading dock safety. Mounted outside in close proximity to the Salvo External Traffic Light, the Salvo Traffic Light Sign informs the driver when it is safe to depart from the loading dock.

### Technical Data

<b>Product Material</b>	Laminated
<b>Dimensions</b>	10" W x 2' 4" H x 1/4" D
<b>Weight</b>	2 lb
<b>Color</b>	OSHA Safety Yellow

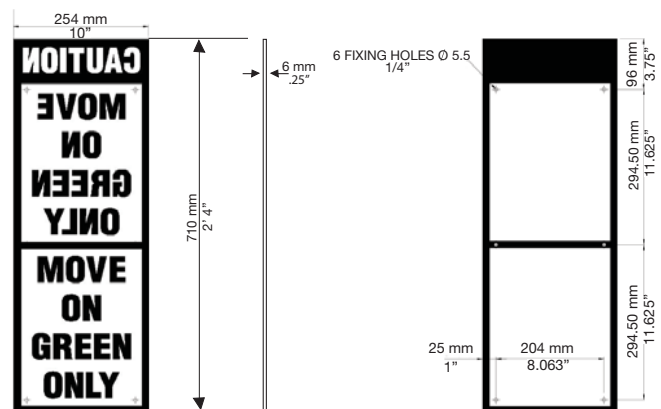

### Order Information

P/N	Description
510.0032	Salvo Traffic Light Sign

### Contact Information

Castell Interlocks, Inc.  
 21 Kenton Lands Road  
 Erlanger, KY 41018  
 phone: +1.859.341.3075  
 fax: +1.859.957.1577  
 toll free: +1.877.341.3075  
 www.castell.com

580.0018



### Description

The Salvo Glad Hand Lock Enclosure - Exterior is designed to store a single Salvo Glad Hand Lock when not in use. The Salvo Glad Hand Lock Enclosure can be quickly wall-mounted or attached to a Salvo Bollard. The enclosure is weather-resistant, protecting the Salvo Glad hand Lock even in a harsh environment.

### Application

Part of the Salvo product line, the Salvo Glad Hand Lock Enclosure - Exterior stores a Salvo Glad Hand Lock. Mounted to the wall or a Salvo Bollard outside, the Salvo Glad Hand Lock Enclosure stores and protects a Salvo Glad Hand Lock when it is not being used on a truck's airline.

### Technical Data

<b>Temperature Rating</b>	min -20° F / max 175° F
<b>Product Material</b>	Stainless Steel
<b>Dimensions</b>	12" H x 8" W x 6" D
<b>Weight</b>	6 lb
<b>Closing Handle</b>	Handle with Key Lock

#### Mounting Hole Pattern

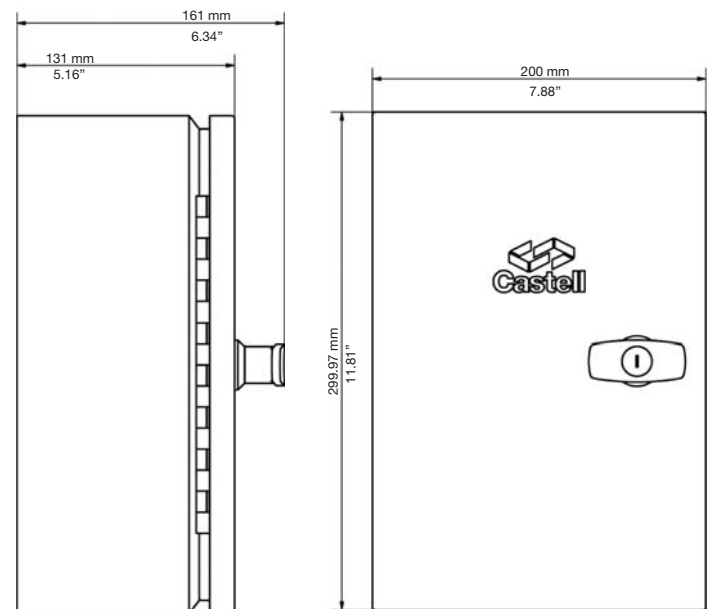
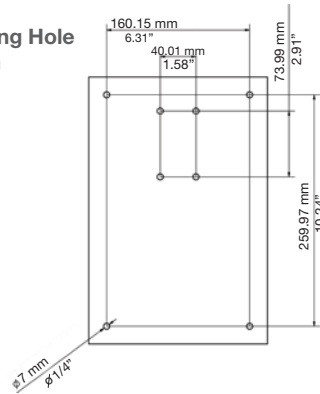

### Order Information

#### P/N

510.0004

#### Description

SGL Enclosure - Exterior

### Contact Information

Castell Interlocks, Inc.  
21 Kenton Lands Road  
Erlanger, KY 41018

phone: +1.859.341.3075  
fax: +1.859.957.1577  
toll free: +1.877.341.3075  
www.castell.com

580.0013

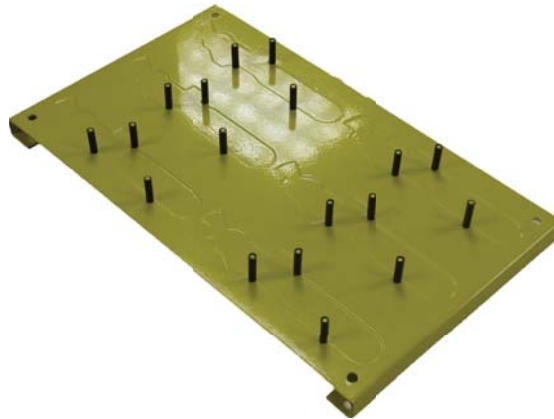

### Description

The Salvo Glad Hand Lock Enclosure - Interior is designed to store six Salvo Glad Hand Locks when not in use. The Salvo Glad Hand Lock Enclosure is wall-mounted. The enclosure is modular and can be combined with other enclosures to store more than six Salvo Glad Hand Locks.

### Application

Part of the Salvo product line, the Salvo Glad Hand Lock Enclosure - Interior stores up to six Salvo Glad Hand Locks. Mounted to the wall inside, the Salvo Glad Hand Lock Enclosure stores Salvo Glad Hand Locks when they are not being used on a truck's airlines.

### Technical Data

<b>Product Material</b>	Cold rolled steel
<b>Color</b>	Powder Coat OSHA Safety Yellow
<b>Dimensions</b>	12" H x 20" W x 1" D
<b>Weight</b>	7 lb

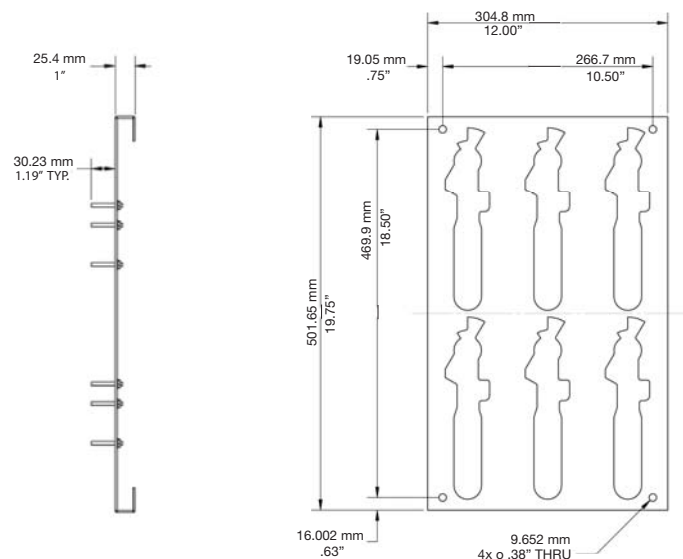

### Order Information

#### P/N

510.0005

#### Description

SGL Enclosure - Interior

### Contact Information

Castell Interlocks, Inc.  
21 Kenton Lands Road  
Erlanger, KY 41018

phone: +1.859.341.3075  
fax: +1.859.957.1577  
toll free: +1.877.341.3075  
www.castell.com

580.0014